







**BUREAU
VERITAS**

TEST REPORT IEC 60730-1

**Automatic electrical controls
– Part 1: General requirements**

Report reference number :	PV200109N021
Date of issue..... :	2020-07-16
Total number of pages..... :	22
Testing laboratory name :	Bureau Veritas Shenzhen Co., Ltd. Dongguan Branch
Address..... :	No. 96, Guantai Road (Houjie Section), Houjie Town, Dongguan City, Guangdong Province, 523942, People's Republic of China
Accreditation..... :	 Certificate # 2951.01
Applicant's name :	Shenzhen SOFAR SOLAR Co., Ltd.
Address..... :	401, Building 4, AnTongDa Industrial Park, District 68, XingDong Community, XinAn Street, BaoAn District, Shenzhen, China.
Test specification	
Test item..... :	FUNCTIONAL SAFETY
Standard..... :	IEC 60730-1+AMD1 Automatic electrical controls –Part 1: General requirements
Test result..... :	The product(s) were found in compliance with the Class B parameters
Test Report Form No..... :	IEC 60730-1
TRF Originator..... :	Bureau Veritas Shenzhen Co., Ltd. Dongguan Branch
Master TRF..... :	Dated 2020-05-12
Test item description :	Rechargeable Li-ion Battery
Trademark..... :	
Model/Type reference :	GTX5000
Ratings :	51.2V, 100Ah, 5120Wh

This report is governed by, and incorporates by reference, CPS Conditions of Service as posted at the date of issuance of this report at <http://www.bureauveritas.com/home/about-us/our-business/cps/about-us/terms-conditions> and is intended for your exclusive use. Any copying or replication of this report to or for any other person or entity, or use of our name or trademark, is permitted only with our prior written permission. This report sets forth our findings solely with respect to the test samples identified herein. The results set forth in this report are not indicative or representative of the quality or characteristics of the lot from which a test sample was taken or any similar or identical product unless specifically and expressly noted. Our report includes all of the tests requested by you and the results thereof based upon the information that you provided to us. Measurement uncertainty is only provided upon request for accredited tests. You have 60 days from date of issuance of this report to notify us of any material error or omission caused by our negligence or if you require measurement uncertainty; provided, however, that such notice shall be in writing and shall specifically address the issue you wish to raise. A failure to raise such issue within the prescribed time shall constitute your unqualified acceptance of the completeness of this report, the tests conducted and the correctness of the report contents.

Testing Location	Bureau Veritas Shenzhen Co., Ltd. Dongguan Branch
Address	No. 96, Guantai Road (Houjie Section), Houjie Town, Dongguan City, Guangdong Province, 523942, People's Republic of China
Tested by (name and signature).....	Lukes Lin 
Approved by (name and signature).....	James Huang 
Manufacturer's name	Shenzhen SOFAR SOLAR Co., Ltd.
Manufacturer address	401, Building 4, AnTongDa Industrial Park, District 68, XingDong Community, XinAn Street, BaoAn District, Shenzhen, China.
BMS Manufacturer	Shenzhen Peicheng Intelligent Control Technology Co., Ltd.

Document History			
Date	Internal reference	Modification / Change / Status	Revision
2020-07-16	Lukes Lin	Initial report was written	0
Supplementary information:			



Test items particulars

Equipment mobility: Use for the industrial applications
 Operating condition.....: Continuous
 Class of equipment.....: Use for the industrial applications
 Mass of equipment [kg].....: Approx.55

Test case verdicts

Test case does not apply
 to the test object: N/A
 Test item does meet
 the requirement.....: P(ass)
 Test item does not meet
 the requirement.....: F(ail)

Testing

Date of receipt of test item.....: 2020-01-09
 Date(s) of performance of test.....: 2020-03-13 to 2020-04-17

General remarks:

The test result presented in this report relate only to the object(s) tested. This report shall not be reproduced in part or in full without the written approval of the issuing testing laboratory.
 "(see Annex #)" refers to additional information appended to the report.
 "(see appended table)" refers to a table appended to the report.
 Throughout this report a comma is used as the decimal separator.

1. Scope of the Investigation

1.1 Applicable Standard(s)

Standard	Edition/Revision Date
IEC 60730-1+AMD1, Automatic electrical controls - Part 1: General requirements	2015

1.2 Product Overview

The model GTX5000 is a battery pack which contains one parallel and sixteen serial connection (1P16S) cells and a battery management system(BMS), and it is mainly used in solar power system. It will be charged when there is residual power in the power grid and it will provide energy for load if the power is not enough. The evaluation focused on the BMS, which is used for managing and monitoring the status of battery. The safety functions include voltage, current and temperature management during charging and discharging mode.

1.3 Safety Function(s) Investigated

Safety Function	Investigation Parameters
Cell Overvoltage Protection : Maximum cell voltage $\geq 3.5 \pm 0.01V$ for 1.0 ± 0.2 sec	Class B
Cell Undervoltage Protection : Minimum voltage $\leq 2.8 \pm 0.01V$ for 1.0 ± 0.2 sec	Class B
Cell Overtemperature Protection under Charging Condition : Maximum temperature $\geq 55 \pm 3^{\circ}C$	Class B
Cell Overtemperature Protection under Discharging Condition : Maximum temperature $\geq 60 \pm 3^{\circ}C$	Class B
Cell Overcurrent Protection under Discharging Condition : Maximum current $\geq 110 \pm 2A$ for 1.5 ± 0.5 sec	Class B
Short current Protection: Maximum current $\geq 150A$, 300us	Class B
Cell Overcurrent Protection under Charging Condition : Maximum current $\geq 55 \pm 2A$ for 1.5 ± 0.5 sec	Class B

1.4 Considerations

The protection thresholds are based on customer's risk analysis and declaration, which shall be evaluated in the end product assessment, including voltage, current and temperature protections.

The software can be remotely updated by PC application in end use. To meet the requirements of IEC 60730-1, the software pack intended to be updated shall be submitted for evaluation before it is published.

The model has only one protection channel to be evaluated, and the other protection channel which realized by communication with end use device was not investigated in this report, this should be evaluated on end product system.

Functions listed in Item 1.3 are relied on firmware and redundant hardware, critical components of safety-related circuit shall be controlled in end-product, refer to item 4.1 hardware and item 5 referenced documents for detail.

2. Product Description

2.1 Functional Safety-Related Hardware

Architectural Design

The BMS has one analog front-end (AFE AN49503A) and one MCU (STM32F072VBT6). AFE is intended to measure cells' voltage/current/temperature parameters and pack voltage as well. In addition, the pack current, one of the cell's temperature and the MOS's temperature can also be sampled by MCU directly for plausibility check of AFE sampling. AFE is configured by MCU at initial stage and it returns measuring data to MCU via a 8-bit SPI interface. MCU is responsible for logic analysis, charge/discharge control and communication with external system. Figure 1 shows the system diagram of BMS.

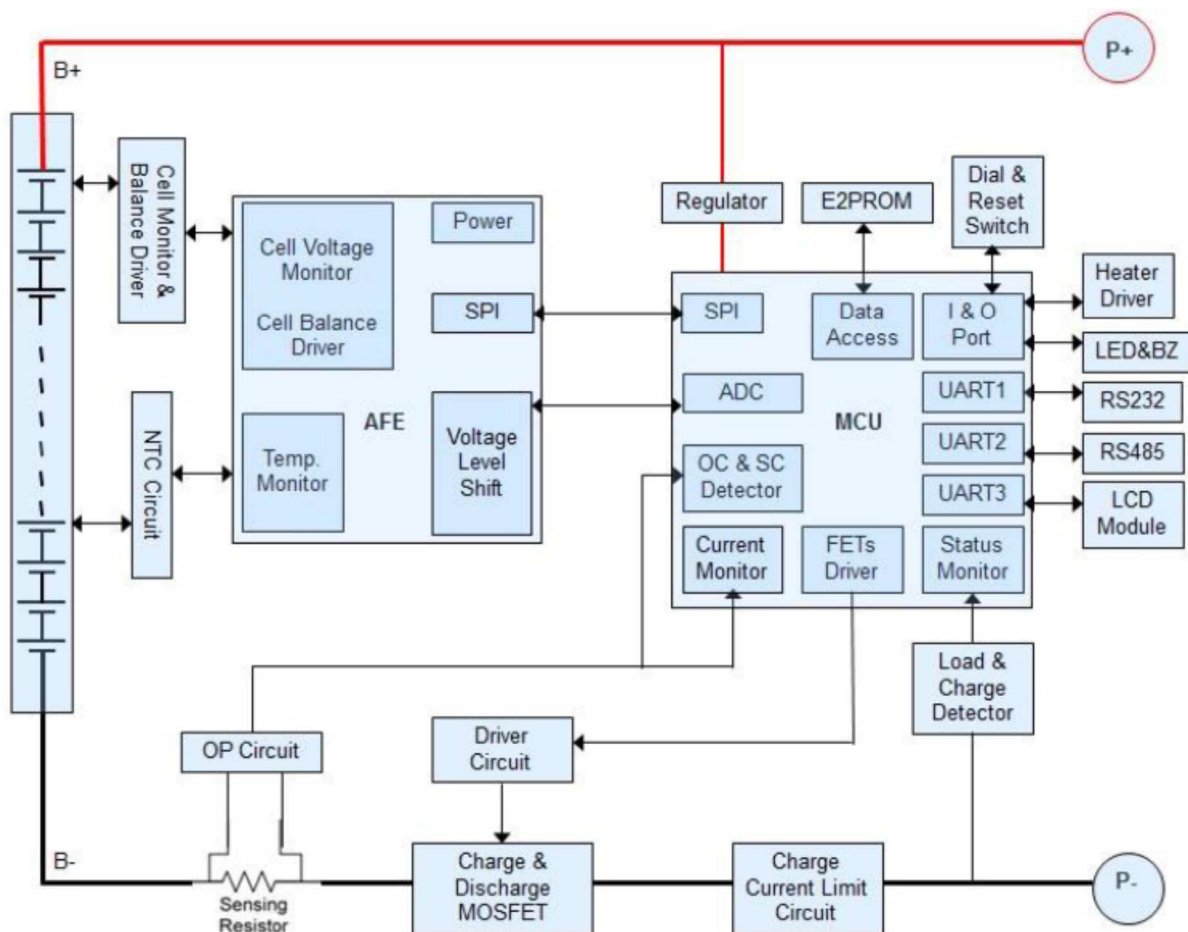

Figure 1 System diagram of BMS

Safety Functions - Hardware

For voltage protection, the AFE is connected to the battery cell directly and all cells' voltage information can be easily detected and processed into digital voltage by the 16-bit ADC of AFE. All voltage values are sent to MCU via a 8-bit SPI interface. If any cell's voltage exceeds the voltage protection threshold, MCU will generate disabled signal to pins PRE_CH, CHG and DSG to cut off the circuit. Furthermore, the MCU can also monitor the total voltage of battery pack, then compare with data obtained by AFE respectively, if they are not match the pin(VBAT) will be set to cut off the circuit.

For current protection, in order to monitor the current in the battery pack, the amplified voltage of resistors RS1 to RS10 between SENSE+ and SENSE- can be measured, and the measured data is sent to AFE and MCU simultaneously. If the measured current exceeds the protection limit, the MCU will disable the charge/discharge like voltage protection.

If any over current happens, the power to MCU will be disconnected permanently, which will make the battery system be maintained in fail-safe mode.

For temperature protection, product is provided with four temperature sensors on battery cell to detect the cell temperature, them are sampled by AFE, also, there are two temperature sensors on BMS board, they are sampled by MCU. if any cell's temperature is higher than the temperature protection limit, the charge/discharge will be disabled to receive temperature protection. Figure 4 shows temperature sampling circuit.

PACK电压与温度采集处理部分

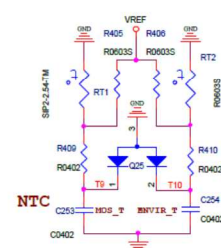
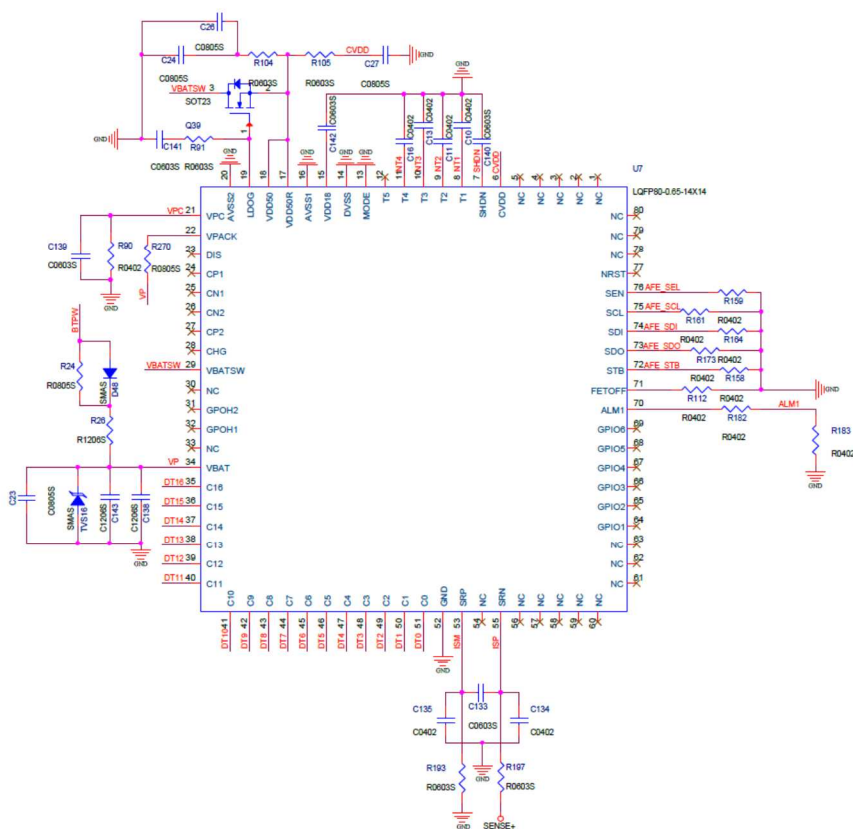

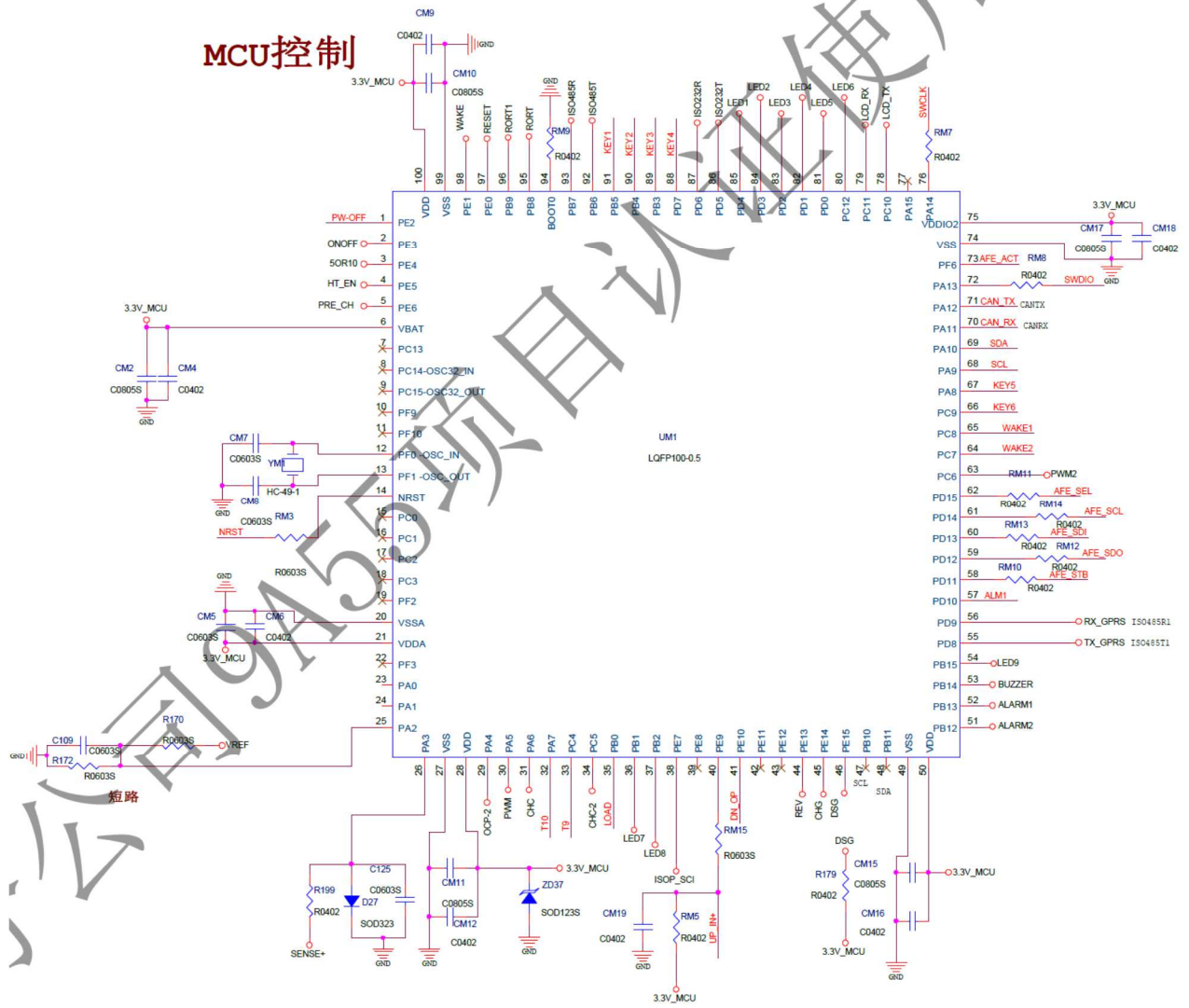

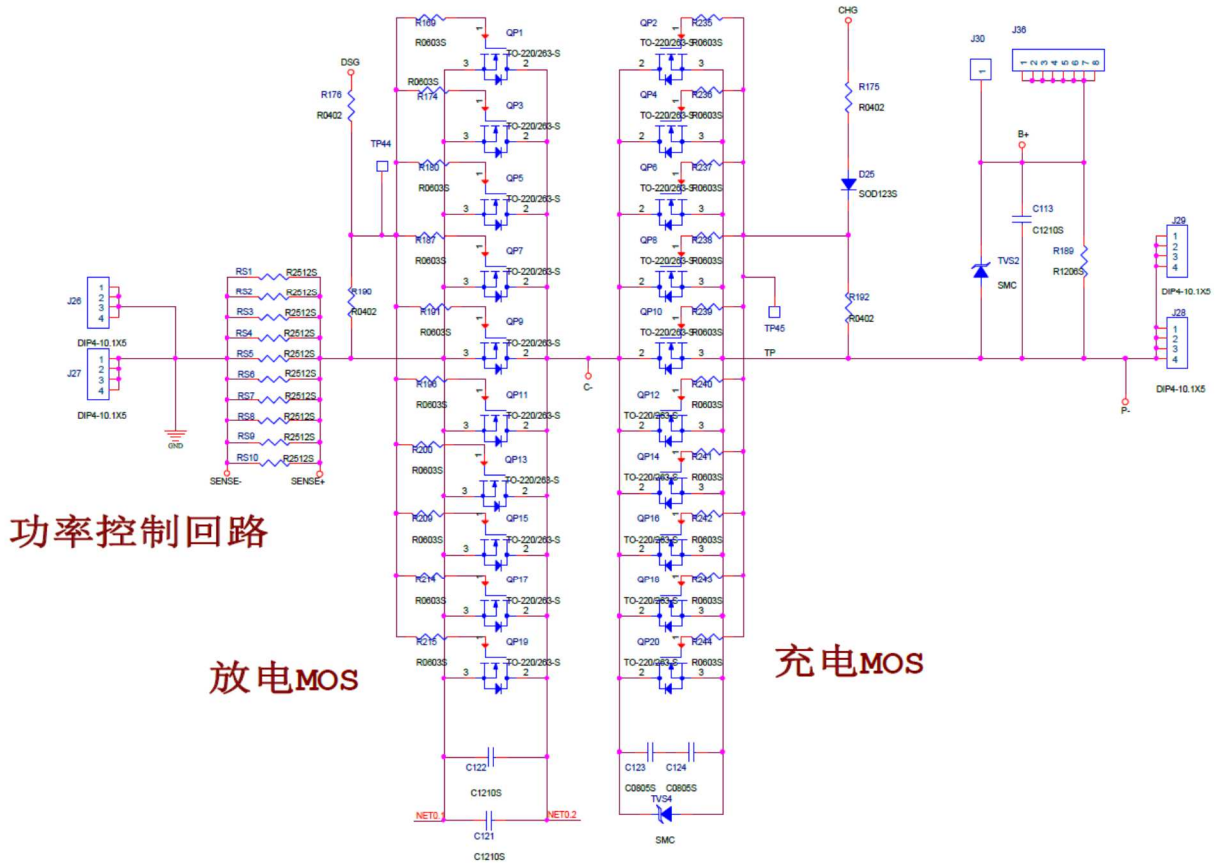

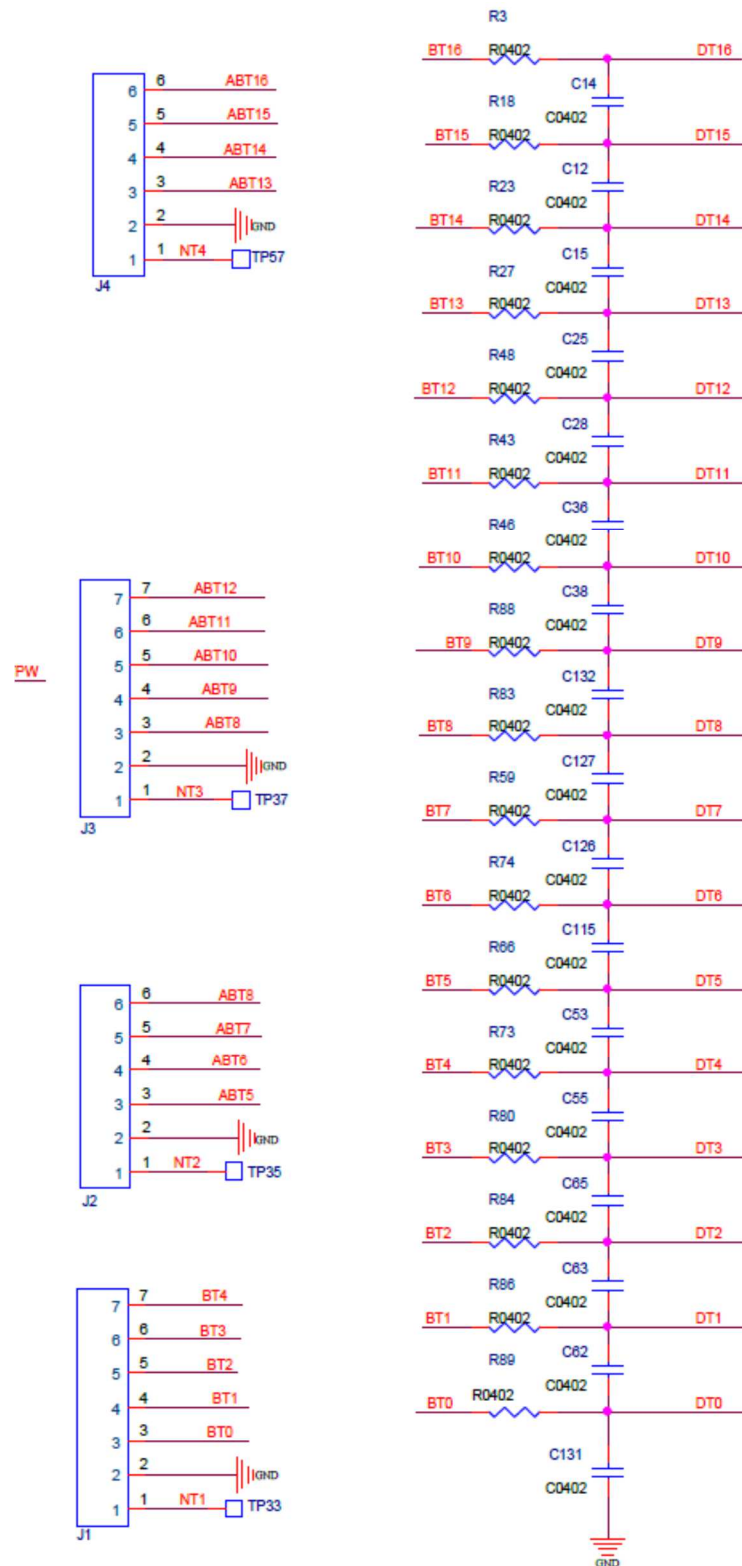
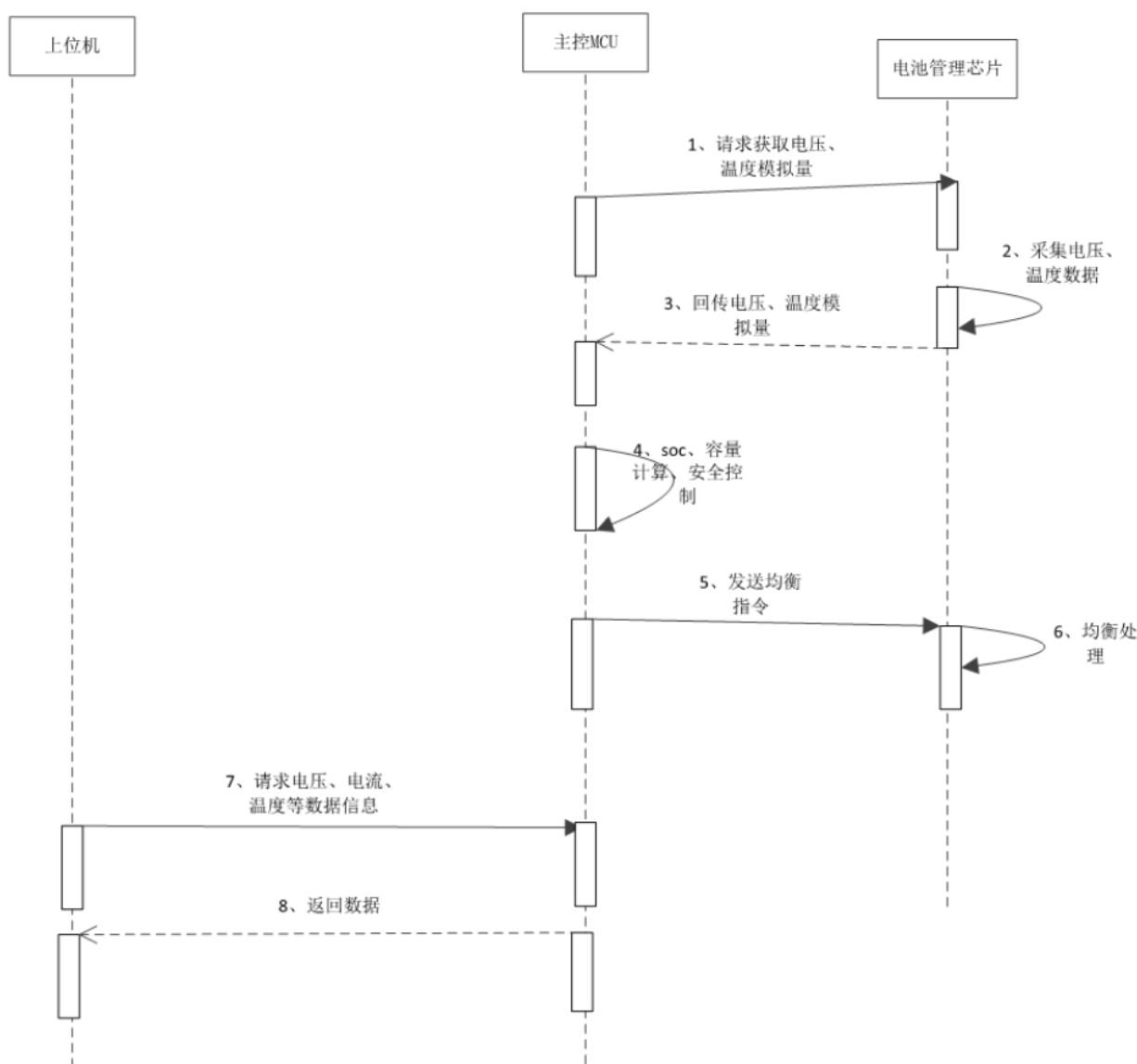

Figure 2 protection circuit

2.2 Functional Safety-Related Software

The firmware of the product is developed by “IAR Embedded Workbench for STMicroelectronics STM8”, which is provided by MCU manufacturer.

The program is initialized to set internal configuration, such as clock, timer, Watch Dog, GPIO, ADC, UART, CAN and Flash, and then voltage/current/temperature limit and delay configuration in AFE is loaded by MCU during startup, product is initialized to a safe state. MCU circularly samples voltage/current/temperature data returned from AFE until protection is required. In addition, the code of addressing microelectronic hardware failure modes is circularly called in the main loop. Figure 3 shows the main flowchart of the program.



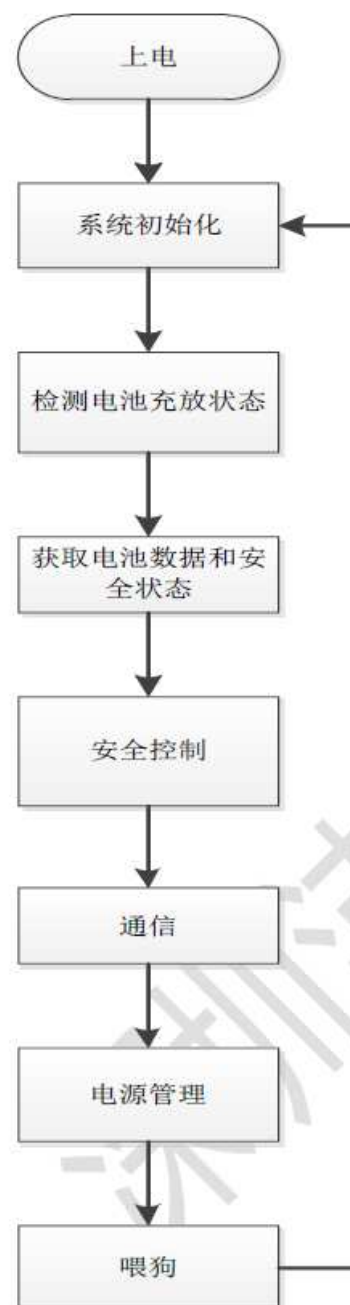
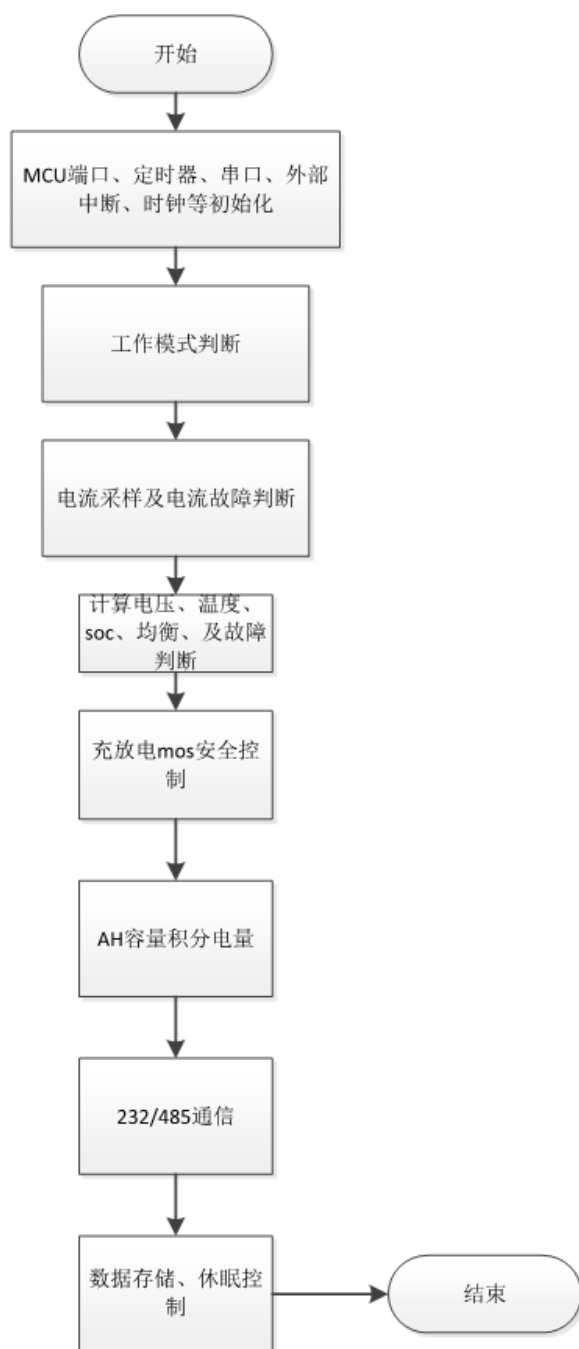

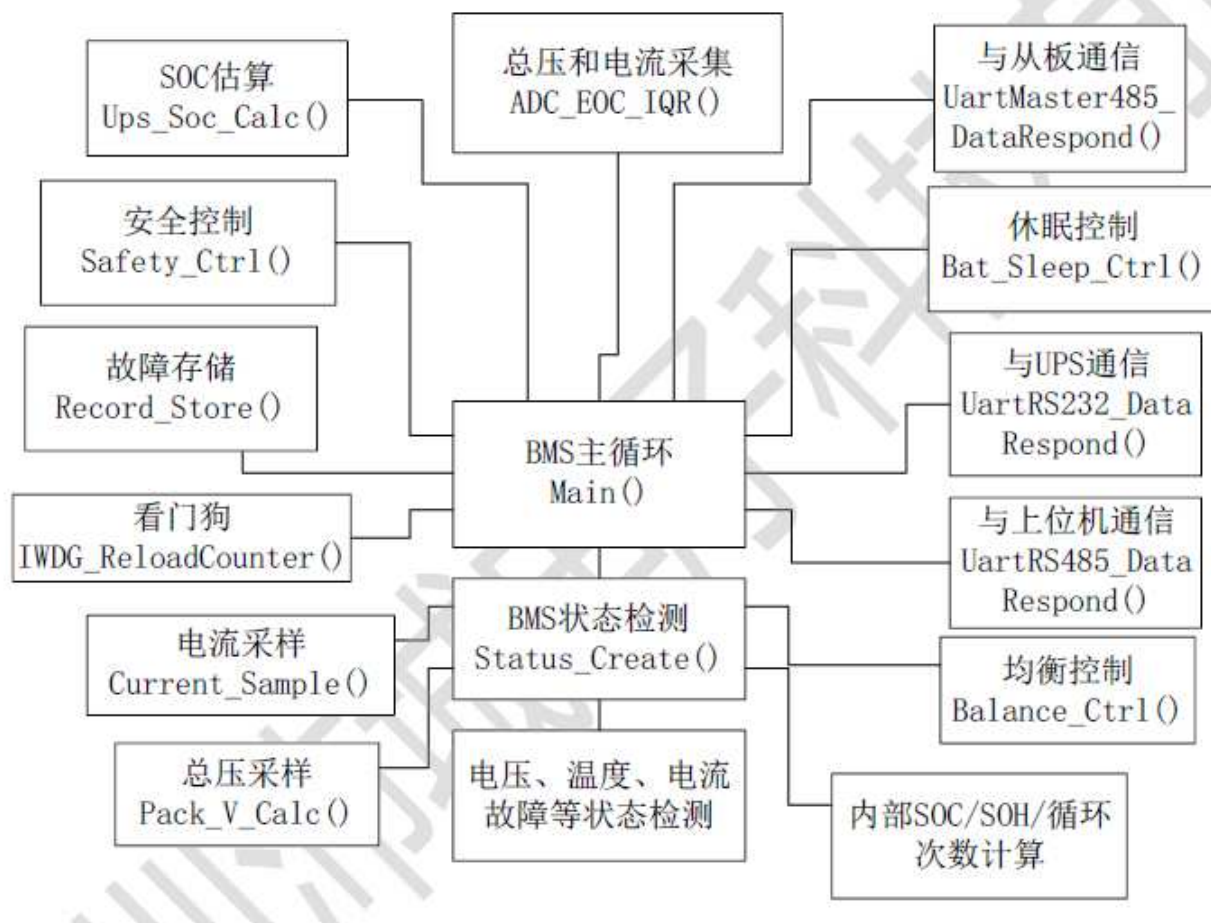

Figure 3 Main flowchart of the program

Safety Functions - Software

The safety functions contain voltage protection, current protection and temperature protection, they have the same protective logic in the software when implemented. If any cell's voltage/current/temperature exceeds the protective limit, the corresponding protective flag will be set and charge/discharge will be disabled within specific delay time.

Take voltage protection for example, the Periodic 100 milli-second Interrupt triggers the cell voltage read function (Void Status_Create (void)) as well as the function for determining max and min cell voltage (void Over_Cell_V_Det(void), void Under_Cell_V_Det(void)), the max and min cell voltage in the pack are determined and their value are stored for comparison with the threshold of overvoltage and undervoltage protection. If the max or min cell voltage exceeds the corresponding limit within the fault limit time (Gmin), the corresponding protection level flag will be set according to the fault severity, and the charge/discharge will be disabled if the flag is BIT1.

The voltage ADC faults in AFE can be detected by comparison between measured whole pack voltage and total voltage of calculating all single cells, the current ADC and temperature ADC fault in AFE can be detected by plausibility check.

Risk Analysis for Microelectronics

TABLE: Microelectronic Hardware Failure Modes			
Software Class			Class 1
Component	Fault/Error	Declared Mitigation Mechanism	Comments
1.0 CPU	-	-	-
1.1 Registers	Stuck-at	Periodic self-test Static Memory Test	Load 0xAAA in all RAM address
1.2 Instruction Decoding and Execution	Overflow	-	-
1.3 Program Counter	Stuck-at	Logical monitoring of the program sequence	Lock-step check
1.4 Addressing	NA	-	-
1.5 Data paths Instruction Decoding	NA	-	-
2. Interrupt Handling and Execution	No interrupt or too frequent interrupt	Time-slot monitoring	Compares counter value of PIT3 with PIT1 and PIT2
3. Clock	Wrong frequency (for quartz synchronized clock: harmonics / subharmonics only)	Frequency monitoring	A reciprocal method of comparing two independent clock sources is used while clocking two timers.
4. Memory	-	-	-
4.1 Invariable Memory	All single-bit faults	Multiple checksum	CRC Check
4.2 Variable Memory	DC fault	Periodic static memory test	Read/write 0x9876 and 0x3456 in all RAM address
4.3 Addressing (relevant to variable and invariable memory)	Stuck-at	See 4.1 & 4.2 above	-
5. Internal data path	-	-	-
5.1 Data	Stuck-at	See 4.1 & 4.2 above	-
5.2 Addressing	Wrong address	See 4.1 & 4.2 above	-



6. External Communication	-	-	-
6.1 Data	Hamming distance 3	CRC – Single word	CRC check for UART
6.2 Addressing	Wrong address	CRC – Single word	CRC check for UART
6.3 Timing	Wrong point in time; wrong sequence	Time-slot monitoring	-
7. Input/Output periphery	Fault condition as specified in end product standard	Plausibility check	-Read back the output state to check
7.1 Digital I/O	N/A	-	-
7.2 Analog I/O	-	-	-
7.2.1 A/D- and D/A- Converter	Fault condition as specified in end product standard	Plausibility check	-
7.2.2 Analog multiplexer	Wrong addressing	Plausibility check	-
8. Monitoring devices comparators	NA	N/A	-
9.0 Custom chips eg. ASIC, GAL, Gate Array	Any output outside the static and dynamic functional specification	N/A	-

3. Requirements Checklist(s)

Sec.	Requirement	Comments	Verdict
H.11.12.3.1	General-Process definition	There is a standardized process of the firmware development. Detailed information can be found in document "General-Process definition" and "Software configuration plan".	P
H.11.12.3.2.1	software safety requirements	All safety related functions have been described, and most protections have redundant solution. All risks have been analyzed, including failure of safety circuit and internal faults of the microelectronics. Detailed information can be found in documents "Software Requirements Specification" and "Software design summary". Document "The Detailed System Diagram Description" shows the description of interfaces between software and hardware.	P
H.11.12.3.2.2	software architecture	Detailed information can be found in "Software design summary".	P
H.11.12.3.2.3	model design and coding	Software is refined into modules based on the architecture design and software requirements, and software code is structured. Detailed information can be found in "Software design" and "PRQA Rule Compliance Report "	Pass
H.11.12.3.2.4	Design and coding standard	This part was inspected during on-site audit by partly code review. The software code was well meet the coding standard. Detailed information can be found in "Rules of software coding".	Pass
H.11.12.3.3	Testing	The firmware was tested by multiple measures, code review, module test and integrating test are conducted, and test cases, test data and test results are documented. Detailed information can be found in "BMS Software test report".	Pass
H.11.12.3.4.1	Tools, programming languages	Detailed information can be found in "Software development tools".	Pass

Sec.	Requirement	Comments	Verdict
H.11.12.3.4.2	Manage of software versions	According to the document "Software version management", all versions are uniquely identified for traceability. Detailed information can be found in and "Software version update lists".	Pass
H.11.12.3.4.3	Software modification	It's the first version to be evaluated.	N/A
H.11.12.4	Remotely actuated control functions	The software can be remotely updated in the end use, and CRC is used for checking. Detailed information can be found in "Software version management".	Pass
H.26.4	Harmonics and Interharmonics Including Mains Signalling at A.C. Power Port, Low Frequency Immunity Tests		N/A
H.26.5. 1	Voltage dips, voltage interruptions		N/A
H.26.5.2	Voltage Variation Test		N/A
H.26.6	Test of Influence of Voltage Imbalance		N/A
H.26.8	Surge Immunity Test		Pass
H.26.9	Electrical Fast Transient/Burst Test		Pass
H.26.10	Ring Wave Immunity Test		Pass
H.26.11	Electrostatic Discharge Test		Pass
H.26.12	Radio-frequency Electromagnetic Field Immunity		Pass
H.26.12.2	Immunity to Conducted Disturbances		Pass
H.26.12.3	Immunity to Radiated Disturbances		Pass
H.26.13	Test of Influence of Supply Frequency Variations		N/A

Sec.	Requirement	Comments	Verdict
H.26.14	Power Frequency Magnetic Field Immunity Test		Pass
H.26.15	Evaluation of Compliance		Pass

Test after which Evaluation of Compliance is conducted	Safety Function (Class B or C)	Results/observations
<p>RADIO-FREQUENCY ELECTROMAGNETIC FIELD IMMUNITY – IMMUNITY TO CONDUCTED DISTURBANCES</p> <p>IMMUNITY TO RADIATED ELECTROMAGNETIC FIELDS</p> <p>POWER FREQUENCY MAGNETIC FIELD IMMUNITY TEST</p> <p>ELECTRICAL FAST TRANSIENT/BURST IMMUNITY TEST</p> <p>SURGE IMMUNITY TEST</p> <p>RING WAVE TEST</p> <p>ELECTROSTATIC DISCHARGE TEST</p>	Class B	<p>Declared Values: OVP $\geq 3.5 \pm 0.01V$ for 1.0 ± 0.2 sec</p> <p>Measured Values: 3.501V, 1.06 sec</p> <p>Declared Values: UVP $\leq 2.8 \pm 0.01V$ for 1.0 ± 0.2 sec</p> <p>Measured Values: 2.792 V, 1.12 sec</p> <p>Declared Values: OTP/C $\geq 55 \pm 3^{\circ}C$</p> <p>Measured Values: 50.3$^{\circ}C$</p> <p>Declared Values: OTP/DC $\geq 60 \pm 3^{\circ}C$</p> <p>Measured Values: 60.1$^{\circ}C$</p> <p>OCP/DC $\geq 110 \pm 2A$ for 1.5 ± 0.5 sec</p> <p>Measured Values: 110A, 1.8 sec</p> <p>SOCP/DC $\geq 150A$,</p> <p>Measured Values: 150A, immediately</p> <p>OCP/C $\geq 55 \pm 2A$ for 1.5 ± 0.5 sec</p> <p>Measured Values: 56A 1.8 sec</p>
<p>COMPOSITE OPERATIONAL AND THERMAL CYCLING TEST</p> <p>EFFECTS OF SHIPPING AND STORAGE TEST</p>	Class B	<p>Declared Values: OVP $\geq 3.5 \pm 0.01V$ for 1.0 ± 0.2 sec</p> <p>Measured Values: 3.499V, 1.02 sec</p> <p>Declared Values: UVP $\leq 2.8 \pm 0.01V$ for 1.0 ± 0.2 sec</p> <p>Measured Values: 2.794 V, 1.12 sec</p> <p>Declared Values: OTP/C $\geq 55 \pm 3^{\circ}C$</p> <p>Measured Values: 55.3$^{\circ}C$</p> <p>Declared Values: OTP/DC $\geq 60 \pm 3^{\circ}C$</p>



		<p>Measured Values: 60.2°C</p> <p>OCP/DC $\geq 110 \pm 2A$ for 1.5 ± 0.5 sec</p> <p>Measured Values: 111A, 1.7 sec</p> <p>SOCP/DC $\geq 150A$,</p> <p>Measured Values: 150A, immediately</p> <p>OCP/C $\geq 55 \pm 2A$ for 1.5 ± 0.5 sec</p> <p>Measured Values: 56A 1.8 sec</p>
--	--	---

Supplementary information:

Note (*): The function was verified without checking detailed action temperature, since the temperature switch was certified by IEC/EN, and also will be controlled by end-product engineer. The protection function performed as required during the test.

4. Functional Safety-Related Components

4.1 Hardware

Schematic Ref. No.	Function	Manufacturer	Model
U17	AFE	Panasonic	AN49503A
UM1	MCU	ST	STM32F072VBT6
RS1 to RS10	Resistor	--	--
TP 33, TP35, TP37, TP57	NTC	SUNLORD	SNEP2103F3435FB030A
QP4, QP6, QP8, QP10, QP12, QP14, QP16, QP18, QP20	MOSFET	--	MDE10N026RH
QP3, QP5, QP7, QP9, QP11, QP13, QP15, QP17, QP19	MOSFET	--	MDE10N026RH

4.2 Software

Model/Module Ref.	Version/Revision	Unique Identifier #
UM1/ AN49503A	1.13	P16S100A-9A55-1.13



5. Referenced Documents

Doc. Name	Doc. #	Ver./Rev./Date
MCU failure analysis	/	A1.0/ 2020/05/19
Component single fault analysis	/	A0/ 2017/12/06
Hardware FMEA analysis for BMS	/	A0/ 2020/01/16
General-Process definition	/	V1.0/2020/03/36
BMS Software Requirements Specification	/	V1.1/20200430
Software design summary	/	V1.1/20200430
Software Design	/	A0/2020/11/29
Function and action signal test report	/	V1.0/20200509
Software test report	/	V1.0/ 20200430
Software development tools	/	V1.0/ 20200430
Software version update lists	/	V1.0/ 20200430
Software version management	/	V1.0/ 20200430
Rules of software coding	/	V1.0/ 20200430
The Detailed System Diagram	/	-

The test report is invalid without the signature of the approver and the company's seal.
The test results presented in this report relate only to the samples submitted.
Partial reproduction is not allowed without the written approval of the laboratory.